



Refrigeration  
and  
deep-freezing

# Compressor cooling

## Powerful and durable

### Even at extreme outside temperatures

Excellent cooling performance regardless of the ambient temperature, versatile use – these are the distinguishing features of a compressor cooler. Choose from a large and well-proven range that leaves nothing to be desired. It extends from low-cost 230-volt basic models to built-in coolers for kitchenettes. All units are designed for mobile use and are as powerful as a domestic fridge.

- | Most powerful and most durable cooling in mobile and “stationary” use
- | Excellent cooling performance even at extreme ambient temperatures
- | Suitable for deep-freezing
- | Energy saving and superbly quiet operation
- | Impeccable operation in inclined position
- | Suitable for operation with a solar panel

## Compressor technology

Compressor cooling appliances work with a CFC-free refrigerant that changes from liquid to gas as it flows through the evaporator. In the process the evaporator extracts heat from the refrigeration compartment – it's getting cold. The compressor draws in the gaseous refrigerant, compresses it and passes it on to the condenser. Here, the absorbed heat is released to the atmosphere. The refrigerant changes to the original liquid state and flows back to the evaporator, where the cycle starts again.

- | Problem-free operation with 12/24 volts DC or 12/24 volts and 100 – 240 volts AC
- | Refrigeration and deep-freezing
- | Excellent cooling performance even at extreme outside temperatures
- | Minimal power consumption
- | Integrated battery protection
- | Ideal for solar operation

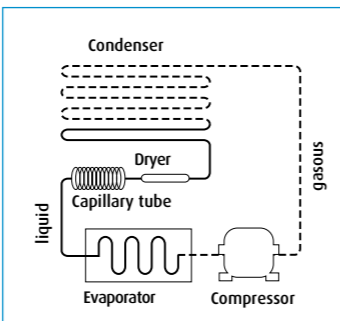

## High-performance basic cooler

Excellent cooling and freezing performance regardless of the ambient temperature. Sturdy, functional, energy-saving. 40 litres capacity. Connection to 230 V AC mains socket – ideal for camping, leisure or as a stand-by freezer at home.

### WAECO CoolFun CK

Pages 32 – 33



CoolFun CK-40D

## Super-compact compressor coolers

Favourably priced entry-level compressor coolers. With performance and handling qualities that will ensure you will enjoy their benefits for years to come. Refrigeration and deep-freezing, 10.5 to 23 litre capacity. In addition, they feature a compact design which fits where others won't.

### WAECO CoolFreeze CDF

Pages 34 – 37



CoolFreeze CDF-11

CoolFreeze CDF-18

CoolFreeze CDF-25

## High-tech coolers

Pages 38 – 42

Unbeatable performance in all mobile applications. Excellent cooling and deep-freezing even at extreme ambient temperatures. Compact dimensions, energy-saving and quiet operation. Available in sizes from 31 to 106 litres, for 12/24 volts DC and 100 – 240 volts AC.

### WAECO CoolFreeze CF



CoolFreeze CF-35

CoolFreeze CF-40

CoolFreeze CF-50

CoolFreeze CF-60

CoolFreeze CF-80

CoolFreeze CF-110

## Fridge/freezer with rechargeable battery

Super-cool – even if there's no external power available. Up to 18 hours independent operation with integrated battery, which can be recharged from the vehicle battery or a mains socket (optional mains adapter). With mains priority circuit and other comfort features.

### WAECO CoolFreeze CF

Page 43



CoolFreeze CF-32UP

## Built-in coolers

WAECO CoolMatic CB built-in coolers are opened from the top. Featuring detachable cooling units, they are extremely compact and therefore ideal for installation in kitchenettes or benches.

### WAECO CoolMatic CB

Pages 48 – 49



CoolMatic CB-36



CoolMatic CB-40



## For camping, home and leisure

Powerful compressor cooler for 230 volts



This portable fridge not only cools your drinks, it will keep frozen food reliably "on ice". The temperature is continuously variable from +10°C to -15°C.

The WAECO CoolFun CK-40D compressor cooler can be a genuine alternative to an absorption unit. Ready for operation on 12 volts, 230 volts or gas, absorption coolers are very flexible in use. However, their cooling performance will largely depend on the ambient temperature.

The CoolFun CK-40D, by contrast, provides extraordinary energy efficiency even at high outside temperatures. It is the best choice if you are looking for a portable 230-volt cooler with excellent performance and low power consumption.

### WAECO CoolFun CK-40D

High-performance compressor cooler for 230 volts

4.21



<b>Gross capacity</b>	approx. 40 litres
<b>Voltage</b>	230 volts AC
<b>Power consumption</b>	approx. 75 watts
<b>Average running time</b>	20% at +20°C ambient temperature 25% at +32°C ambient temperature both at +5°C interior temperature
<b>Temperature range</b>	+10°C to -15°C
<b>Insulation</b>	CFC-free polyurethane foam
<b>System</b>	Powerful AC compressor, aluminium rollbond evaporator, statically ventilated wire tube condenser
<b>Material</b>	Cabinet in coated sheet steel Base and upper components in plastic
<b>Colour</b>	Silver/anthracite
<b>Weight</b>	approx. 22 kg
<b>Quality features</b>	Refrigeration and deep-freezing, electronic thermostat with digital temperature display, wear-free refrigeration circuit, lid with all-round rubber seal and magnetic closure, quick-chill functionality thanks to powerful AC compressor and extra-strong insulation
<b>Test marks</b>	CE, TÜV/GS

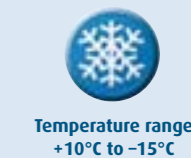

With digital temperature display

Powerful AC compressor

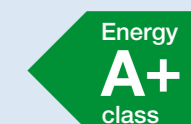

at +5°C interior temperature and +25°C ambient temperature

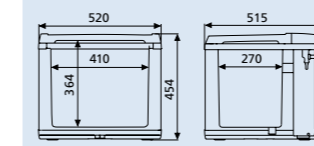

Product	Ref. No.
CoolFun CK-40D	CK-40D-230

## Cooler and freezer all in one: for indoors or out, every day and holiday

The multi-purpose fridge/freezer CoolFun CK-40D is a highly efficient quick chiller. It comes with a powerful AC compressor, extra-strong insulation and an all-round rubber seal. The cooling temperature is continuously variable from +10°C to -15°C. Wear-free refrigeration circuit. Ready for connection to 230 volts.



Easy-to-read digital temperature display

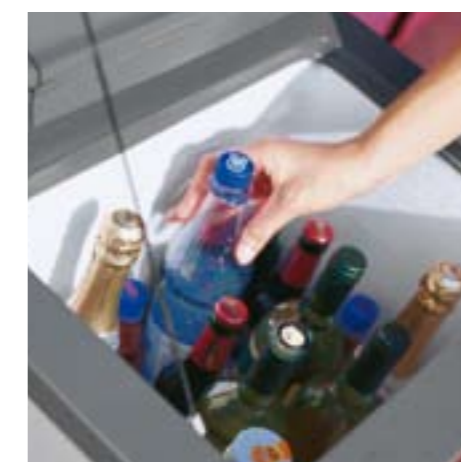

Room for it all: even for 2-litre bottles standing upright



Safe storage of sensitive food: deep-freezing up to -15°C



## Ice-cold mobility!

Slimline compressor coolers at nice prices

The three coolers in the WAECO CoolFreeze CDF series like to travel as much as you do. And are as hassle-free to handle as a thermoelectric cooler. Its remarkably low weight, shoulder strap, and carry handle/s make it absolutely "portable" and ready to go anywhere. And stowage won't ever be a problem: the highly compact design means it will fill any niche perfectly. Additional plus points really start to add up when it comes to performance: refrigeration and deep-freezing up to -18°C with minimal energy consumption! And the pricing? So convincing that you won't be able to resist ...

### The benefits of the WAECO CoolFreeze CDF at a glance:

- › **Excellent cooling and deep-freezing** even at extreme outside temperatures
- › **Slim, slender design**
- › **Very comfortable to carry**
- › **Energy saving and superbly quiet operation**
- › **Impeccable operation in inclined position**
- › **12/24 volts DC**
- › 230-volt connection with low-priced mains adapter
- › **Suitable for operation with a solar panel**

## The compressor sensation

All the advantages now available in pocket-size format!

The WAECO CoolFreeze CDF-11, which is suitable for deep-freezing, represents a new era in the world of compressor coolers. And that in a size which previously seemed impossible. As incredibly compact as a thermoelectric BordBar and therefore an optimum fit – in corners, cabinets and in (towing) vehicles – strapped in on the passenger or rear seat. 10.5 litre volume, refrigeration and deep-freezing down to -18°C, regardless of high ambient temperatures. Only 8.8 kg in weight, and the shoulder strap makes it comfortable to carry.



### WAECO CoolFreeze CDF-11

Portable compressor cooler for refrigeration and deep-freezing

4.29

<b>Gross capacity</b>	approx. 10.5 litres
<b>Voltage</b>	12/24 volts DC
<b>Power input</b>	approx. 30 watts
<b>Temperature range</b>	+10°C to -18°C, continuously variable via electronic thermostat
<b>Power consumption</b>	0.36 kWh/24 h
<b>Insulation</b>	CFC-free polyurethane foam
<b>System</b>	Compressor with integrated control electronics, low voltage protection (can be disabled), electronic fuse/automatic reverse pole protection
<b>Material</b>	Housing and lid PP
<b>Colour</b>	Pale grey/dark grey
<b>Weight</b>	approx. 8.8 kg
<b>Quality features</b>	Electronic thermostat with digital temperature display, 3-stage battery monitor, LED interior light, adjustable shoulder strap, two drink holders, easy and secure fastening with the vehicle safety belt
<b>Scope of delivery</b>	DC connection cable
<b>Test mark</b>	CE, e-approved to 2006/28/EC (Automotive EMC Directive)

**NEW**

**Temperature range +10°C to -18°C**

**Suitable for solar operation**

**Extremely compact design**

**Two integrated drink holders**

**Securely fastened in a vehicle using the vehicle's own seat belts**

**230-volt connection with low-priced mains adapter (pages 90 - 93)**

Product	Ref. No.
CoolFreeze CDF-11	9105100007
<b>Optional extras:</b> Mains adapter 230 V > 24 V	EPS-100W



Two practical drink holders, convenient access with one hand



Enough room for the day's provisions, extra compartment for small snacks



Display with digital temperature readout



Connection cable for 12/24 volts DC, battery monitor can be disabled

## Compressor cooling "light"

Fridge and freezer all in one

Another "flyweight": the WAECO CoolFreeze CDF-18 is also remarkably light for a compressor cooler. At just 11.5 kg, it is extremely comfortable to transport using the sturdy carry handle. Thanks to optimised interior and exterior dimensions, the cooler provides a whopping 18 litre capacity and easily holds 2-litre bottles. In terms of performance, the CDF-18 qualifies as a true heavyweight: refrigeration and deep-freezing up to -18°C with minimal energy consumption!



The truly portable fridge/freezer

### WAECO CoolFreeze CDF-18

Portable compressor cooler for refrigeration and deep-freezing

4.29



<b>Gross capacity</b>	approx. 18 litres
<b>Voltage</b>	12/24 volts DC
<b>Power input</b>	approx. 35 watts
<b>Average running time</b>	10% at +20°C ambient temperature 18% at +32°C ambient temperature both at +5°C interior temperature
<b>Power consumption</b>	Power input x average running time
<b>Temperature range</b>	+10°C to -18°C, continuously variable via electronic thermostat
<b>Insulation</b>	CFC-free PU foam
<b>System</b>	Compressor with integrated control electronics, low-voltage protection adjustable for leisure or starter battery by means of a slide switch, electronic fuse/automatic reverse pole protection, dynamically ventilated wire tube condenser, aluminium rollbond evaporator
<b>Material</b>	Cabinet: PP; lid: PE
<b>Colour</b>	Body: pale grey/dark grey; lid: dark grey
<b>Weight</b>	approx. 11.5 kg
<b>Quality features</b>	Detachable fold-up lid, sturdy carrying handle, vertical space for standing 2-litre bottles
<b>Scope of delivery</b>	DC connection cable
<b>Test marks</b>	CE, TÜV/GS, e-approved to 2006/28/EC (Automotive EMC Directive)



Temperature range +10°C to -18°C



Suitable for solar operation

Energy saver: short running times with reinforced insulation: consumes only 0.29 Ah/h to reach +5°C interior temperature at +20°C ambient temperature

Insulating protective cover as accessory (page 45)

230-volt connection with low-priced mains adapters (pages 90 - 93)

Product	Ref. No.
CoolFreeze CDF-18	9105100002
<b>Optional extras</b>	
Mains adapter 230 V > 24 V	EPS-100W
Insulating protective cover	IC-CF-18

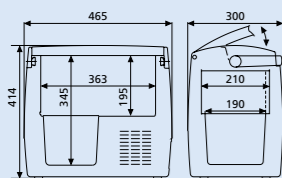

Easy to operate, secure closing mechanism



Robust, elegant, extremely comfortable carrying handle



Vertical insertion of the folding grid: space for standing 2-litre bottles



Salad underneath, bottles above: the horizontal folding grid arranges everything



Left: continuously variable electronic thermostat; right: two-stage battery monitor

## Fits into every niche

Slim size, nice price

It fits where others won't: with its tall and slim design, the WAECO CoolFreeze CDF-25 effortlessly slides into narrow gaps and niches in your (recreational) vehicle. It can be secured in place by a fixing kit - available as an optional extra. It is convenient to transport and provides 23 litres capacity for refrigeration or deep-freezing. Power consumption? Minimal. All in all, a cool insider tip for price-conscious buyers!



Extremely economical!

### WAECO CoolFreeze CDF-25

Compressor cooler for refrigeration and deep-freezing

4.29



<b>Gross capacity</b>	approx. 23 litres (19 l for refrigeration/deep-freezing, 4 l for fresh food)
<b>Voltage</b>	12/24 volts DC
<b>Power input</b>	approx. 35 watts
<b>Average running time</b>	15% at +20°C ambient temperature 19% at +32°C ambient temperature both at +5°C interior temperature
<b>Power consumption</b>	Power input x average running time
<b>Temperature range</b>	+10°C to -18°C, continuously variable via electronic thermostat
<b>Insulation</b>	CFC-free PU foam
<b>System</b>	Compressor with integrated control electronics, low voltage protection adjustable for leisure and starter battery by means of a slide switch, electronic fuse/automatic reverse pole protection, dynamically ventilated wire tube condenser, aluminium rollbond evaporator
<b>Material</b>	Cabinet: PP; lid: PE
<b>Colour</b>	Body: pale grey/dark grey; lid: dark grey
<b>Weight</b>	approx. 12.5 kg
<b>Quality features</b>	Detachable lid (lid mount at the front), vertical space for standing 2-litre bottles, interior light
<b>Scope of delivery</b>	DC connection cable, detachable wire basket
<b>Test marks</b>	CE, TÜV/GS, e-approved to 2006/28/EC (Automotive EMC Directive)



Temperature range +10°C to -18°C



Suitable for solar operation

Slim body - minimal space consumption

Insulating protective cover and fixing kit as accessories (pages 44 - 45)

230-volt connection with low-priced mains adapters (pages 90 - 93)

Product	Ref. No.
CoolFreeze CDF-25	9105100003
<b>Optional extras</b>	
Mains adapter 230 V > 24 V	EPS-100W
Universal fixing kit	UFK-C
Insulating protective cover	IC-CF-25

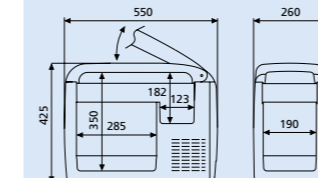

Closing mechanism: easy to use and super-safe



Left: continuously variable electronic thermostat; right: two-stage battery monitor



Robust lid hinge, sturdy injection moulded cabinet



Space for upright storage of 2-litre bottles across the entire base



## Premium boxes for all applications

High-tech unlimited

Compressor technology at its best – that’s the term used to describe the **CoolFreeze series coolers CF-35 to CF-110**. **The high-performance appliances can be operated on almost any mains network.** Whether 12, 24, 100 or 240 volts – the integrated power supply unit recognises each voltage and adjusts itself accordingly.

CoolFreeze CF series coolers feature optimised dimensions and are easy to transport. Their generous capacity makes them ideal for use in motorhomes and caravans, on boats or yachts – wherever mobile refrigeration is required.

Optional accessories include **fridge slides** for convenient slide-out access and a **fixing kit** for a firm and secure hold in the vehicle.

**CoolFreeze CF-35 to CF-110 – the significant benefits at a glance:**

- › **CF special electronics with digital temperature display**
- › **12/24 volts DC and 100 – 240 volts AC**
- › **Excellent cooling performance** even at extreme ambient temperatures
- › **Deep-freeze functionality**
- › **Energy saving and superbly quiet operation**
- › **Impeccable operation in inclined position**
- › **Suitable for operation with a solar panel**

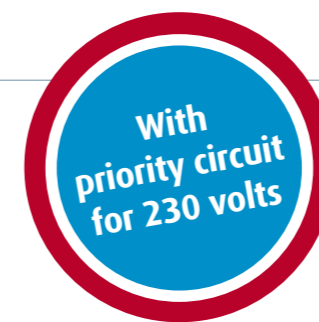

CoolFreeze CF-35

CoolFreeze CF-40

CoolFreeze CF-50

**NEW!** CoolFreeze CF-60

CoolFreeze CF-80

CoolFreeze CF-110

### CF special electronics with digital temperature display, soft start and turbo cooler

The six CoolFreeze coolers CF-35 to CF-110 are equipped with the CF special electronics system featuring the following functions:

- › **Intelligent, automatic turbo cooler**
- › **3-stage battery protection to be set on the digital display**
- › **4-digit display readout**
- › **Digital display in Celsius or Fahrenheit**
- › **Free temperature setting on the display**
- › **Display of current interior temperature**
- › **Status and error indication by 2 separate LEDs**
- › **Memory function saves the last settings**

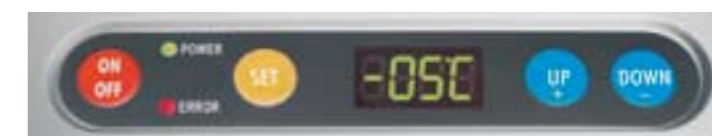

**Turbo power with economy.** The CF special electronics system gives the compressor a soft and power-saving start at 2500 rpm. If the preset temperature is not reached within a short period of time or a temperature below -12°C has been set, the turbo cooler switches on automatically to boost the compressor speed. As soon as a preset temperature up to -12°C has been reached, the system switches back to economy mode (except if a temperature below -12°C has been set).

**The outcome:** fast yet economical cooling from +10°C to -18°C.



Standard interior light for a clear overview in the dark



Ready for connection to 12/24 volts DC and 100 – 240 volts AC with mains priority circuit



A smart organiser: detachable wire basket (all models except CF-35); CF-40/CF-50: wire basket with grid divider



Convenient transport with ergonomically shaped recessed grips and sturdy, detachable handles

› **Fridge slides and fixing kit as accessory (p. 44)** › **Insulating protective covers as accessory (p. 45)**

**WAECO CoolFreeze CF-35**

Compressor cooler for refrigeration and deep-freezing with CF special electronics

4.10



<b>Gross capacity</b>	approx. 31 litres (26.5 l for refrigeration/deep-freezing, 4.5 l for fresh food)
<b>Voltage</b>	12/24 volts DC and 100 – 240 volts AC
<b>Power consumption</b>	approx. 45 watts
<b>Average running time</b>	15% at +20°C ambient temperature 19% at +32°C ambient temperature both at +5°C interior temperature
<b>Power consumption</b>	Power input x average running time
<b>Temperature range</b>	+10°C to -18°C, free temperature setting via electronic thermostat with digital temperature readout
<b>Insulation</b>	CFC-free PU foam
<b>System</b>	Fully hermetic Danfoss BD35F compressor with integrated control electronics, low voltage protection adjustable for leisure and starter battery via electronic system, electronic fuse/automatic reverse pole protection, dynamically ventilated wire tube condenser, aluminium rollbond evaporator
<b>Material</b>	Cabinet: PP, lid: PE
<b>Colour</b>	Body: pale grey/dark grey; lid: dark grey
<b>Weight</b>	approx. 15 kg
<b>Quality features</b>	Detachable lid (lid mount at the front), interior light, vertical space for standing 1.5-litre bottles. CF special electronics with soft start and turbo cooler (p. 39)
<b>Scope of delivery</b>	DC and AC connection cables, evaporator grille, detachable carrying handles
<b>Test marks</b>	CE, TÜV/GS, e-approved to 2006/28/EC (Automotive EMC Directive)

Product	Ref. No.
CoolFreeze CF-35	CF-035AC
<b>Optional extras</b>	
Fridge slide, long	SLD-060
Fridge slide, wide	SLD-060W
Universal fixing kit	UFK-C
Insulating protective cover	IC-CF-35

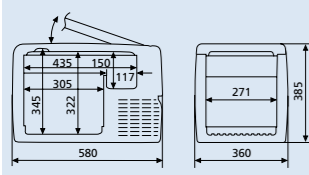

**WAECO CoolFreeze CF-40**

Compressor cooler for refrigeration and deep-freezing with CF special electronics



<b>Gross capacity</b>	approx. 37 litres (31 l for refrigeration/deep-freezing, 6 l for fresh food)
<b>Voltage</b>	12/24 volts DC and 100-240 volts AC
<b>Power input</b>	approx. 45 watts
<b>Average running time</b>	18% at +20°C ambient temperature 22% at +32°C ambient temperature both at +5°C interior temperature
<b>Power consumption</b>	Power input x average running time
<b>Temperature range</b>	+10°C to -18°C, free temperature setting via electronic thermostat with digital temperature readout
<b>Insulation</b>	CFC-free PU foam
<b>System</b>	As for CF-35
<b>Material</b>	Cabinet: PP, lid: PE
<b>Colour</b>	Body: pale grey/dark grey, lid: dark grey
<b>Weight</b>	approx. 16 kg
<b>Quality features</b>	Detachable lid (lid mount at the front), interior light, vertical space for standing 2-litre bottles. CF special electronics with soft start and turbo cooler (p. 39)
<b>Scope of delivery</b>	DC and AC connection cables, removable wire basket, detachable carrying handles
<b>Test marks</b>	CE, TÜV/GS, e-approved to 2006/28/EC (Automotive EMC Directive)

Product	Ref. No.
CoolFreeze CF-40	CF-040AC
<b>Optional extras</b>	
Fridge slide, long	SLD-060
Fridge slide, wide	SLD-060W
Universal fixing kit	UFK-C
Insulating protective cover	IC-CF-40

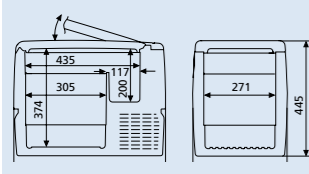

12/24 volts DC and 100 – 240 volts AC

Protective cover, fridge slides and fixing kit as accessories (pages 44 – 45)

CF special electronics with soft start and turbo cooler



**WAECO CoolFreeze CF-50**

Compressor cooler for refrigeration and deep-freezing with CF special electronics

4.10



<b>Gross capacity</b>	approx. 49 litres (41 l for refrigeration/deep-freezing, 8 l for fresh food)
<b>Voltage</b>	12/24 volts DC and 110 – 240 volts AC
<b>Power input</b>	approx. 45 watts
<b>Average running time</b>	15% at +20°C ambient temperature 19% at +32°C ambient temperature both at +5°C interior temperature
<b>Power consumption</b>	Power input x average running time
<b>Temperature range</b>	+10°C to -18°C, free temperature setting via electronic thermostat with digital temperature readout
<b>Insulation</b>	CFC-free PU foam
<b>System</b>	As for CF-35
<b>Material</b>	Cabinet: PP, lid: PE
<b>Colour</b>	Body: pale grey/dark grey; lid: dark grey
<b>Weight</b>	approx. 18 kg
<b>Quality features</b>	Detachable lid (plug-in lid mount, variable left/right), interior light, vertical space for standing 2-litre bottles. CF special electronics with soft start and turbo cooler (p. 39)
<b>Scope of delivery</b>	As for CF-40
<b>Test marks</b>	CE, TÜV/GS, e-approved to 2006/28/EC (Automotive EMC Directive)

Product	Ref. No.
CoolFreeze CF-50	CF-050AC
<b>Optional extras</b>	
Fridge slide, long	SLD-060
Fridge slide, wide	SLD-060W
Universal fixing kit	UFK-C
Insulating protective cover	IC-CF-50

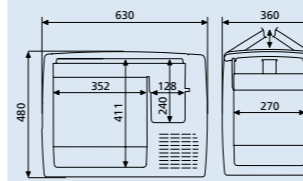

12/24 volts DC and 100 – 240 volts AC

Protective cover, fridge slides and fixing kit as accessories (pages 44 – 45)

**WAECO CoolFreeze CF-60**

Compressor cooler for refrigeration and deep-freezing with CF special electronics



<b>Gross capacity</b>	approx. 59 litres (51 l for refrigeration/deep-freezing, 8 l for fresh food)
<b>Voltage</b>	12/24 volts DC and 100-240 volts AC
<b>Power input</b>	approx. 45 watts
<b>Average running time</b>	18% at +20°C ambient temperature, 22% at +32°C ambient temperature, both at +5°C interior temperature
<b>Power consumption</b>	Power input x average running time
<b>Temperature range</b>	+10°C to -18°C, free temperature setting via electronic thermostat with digital temperature readout
<b>Insulation</b>	CFC-free polyurethane foam
<b>System</b>	see CF-35
<b>Material</b>	Cabinet: PP, lid: PE
<b>Colour</b>	Body: pale grey/dark grey; lid: dark grey
<b>Weight</b>	approx. 21.6 kg
<b>Quality features</b>	Detachable lid (plug-in lid mount, variable left/right), interior light, vertical space for 2-litre bottles, CF special electronics with soft start and turbo cooler (p. 39)
<b>Scope of delivery</b>	DC and AC connection cables, removable wire basket, detachable carrying handles
<b>Test marks</b>	CE, TÜV/GS, e-approved to 2006/28/EC (Automotive EMC Directive)

Product	Ref. No.
CoolFreeze CF-60	CF-060AC
<b>Optional extras</b>	
Fridge slide, long	SLD-060
Fridge slide, wide	SLD-060W
Universal fixing kit	UFK-C
Insulating protective cover	IC-CF-60

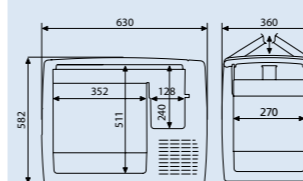

CF-50/CF-60: Detachable lid, folds up transversely, variable lid mounts



CF special electronics with soft start and turbo cooler



**WAECO CoolFreeze CF-80**

Large-capacity cooler for refrigeration and deep-freezing with CF special electronics

4.10



<b>Gross capacity</b>	approx. 80 litres (73 l for refrigeration/deep-freezing, 7 l for fresh food)
<b>Voltage</b>	12/24 volts DC and 100 – 240 volts AC
<b>Power input</b>	approx. 65 watts
<b>Average running time</b>	12% at +20°C ambient temperature 22% at +32°C ambient temperature both at +5°C interior temperature
<b>Power consumption</b>	Power input x average running time
<b>Temperature range</b>	+10°C to -18°C, free temperature setting via electronic thermostat with digital temperature readout
<b>Insulation</b>	CFC-free PU foam
<b>System</b>	Fully hermetic Danfoss BD50F compressor with integrated control electronics, low voltage protection adjustable for leisure and starter battery via electronic system, electronic fuse/automatic reverse pole protection, dynamically ventilated fin condenser, aluminium rollbond evaporator
<b>Material</b>	Cabinet: coated sheet steel, top and base: PP, lid: PE
<b>Colour</b>	Body: pale grey/dark grey, lid: pale grey
<b>Weight</b>	approx. 31 kg
<b>Quality features</b>	Detachable lid (screw-on lid mount, variable left/right), sturdy latches and hinges, interior light, vertical space for 2-litre bottles. CF special electronics with soft start and turbo cooler (p. 39)
<b>Scope of delivery</b>	DC and AC connection cables, removable wire basket, detachable carrying handles
<b>Test marks</b>	CE, TÜV/GS, e-approved to 2006/28/EC (Automotive EMC Directive)

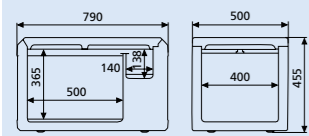

Product	Ref. No.
CoolFreeze CF-80	CF-080AC
<b>Optional extras:</b>	
Fridge slide, long	SLD-110
Fridge slide, wide	SLD-110W
Insulating protective cover	IC-CF-80

**WAECO CoolFreeze CF-110**

Large-capacity cooler for refrigeration and deep-freezing with CF special electronics



<b>Gross capacity</b>	approx. 106 litres (93 l for refrigeration/deep-freezing, 13 l for fresh food)
<b>Voltage</b>	12/24 volts DC and 100 – 240 volts AC
<b>Power input</b>	approx. 65 watts
<b>Average running time</b>	14% at +20°C ambient temperature 25% at +32°C ambient temperature both at +5°C interior temperature
<b>Power consumption</b>	Power input x average running time
<b>Temperature range</b>	+10°C to -18°C, free temperature setting via electronic thermostat with digital temperature readout
<b>Insulation</b>	CFC-free PU foam
<b>System</b>	As for CF-80
<b>Material</b>	Cabinet: coated sheet steel, top and base: PP, lid: PE
<b>Colour</b>	Body: pale grey/dark grey, lid: pale grey
<b>Weight</b>	approx. 33 kg
<b>Quality features</b>	Detachable lid (screw-on lid mount, variable left/right), sturdy latches and hinges, interior light, vertical space for 2-litre bottles. CF special electronics with soft start and turbo cooler (p. 39)
<b>Scope of delivery</b>	DC and AC connection cables, removable wire basket, detachable carrying handles
<b>Test marks</b>	CE, TÜV/GS, e-approved to 2006/28/EC (Automotive EMC Directive)

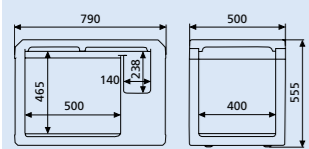

Product	Ref. No.
CoolFreeze CF-110	CF-110AC
<b>Optional extras:</b>	
Fridge slide, long	SLD-110
Fridge slide, wide	SLD-110W
Insulating protective cover	IC-CF-110

Temperature range  
+10°C to -18°C

Suitable for solar operation

12/24 volts DC and 100 – 240 volts AC

Jumbo coolers for personal and professional use

Fridge slides and protective covers as accessories (pages 44 – 45)

CF special electronics with soft start and turbo cooler

**Truly independent**

Integrated battery-run fridge/freezer

Tried-and-tested on Australia's most beautiful and loneliest beaches – and now available here: the CoolFreeze CF-32UP provides refrigeration and deep-freezing up to -18°C. And that's for up to 18 hours without an external power supply!

Far from civilisation and even from your vehicle, the required power is delivered by the **integrated battery** in the compressor cooler. It is charged from the 12- or 24-volt car battery or the mains before use and simply switched on when necessary. The matching mains adapter comes as a separate accessory.



18 hours cooling without power supply

**WAECO CoolFreeze CF-32UP**

Compressor cooler/freezer with rechargeable battery

4.10



<b>Gross capacity</b>	approx. 31 litres
<b>Voltage</b>	12/24 volts DC
<b>Power input</b>	approx. 45 watts (cooling only) approx. 72 watts (cooling and charging)
<b>Charging time</b>	12 to 15 hours
<b>Operation with battery</b>	Up to 18 hours with fully charged battery at +5°C interior and +32°C ambient temperature
<b>Average running time</b>	18% at +20°C ambient temperature 22% at +32°C ambient temperature both at +5°C interior temperature
<b>Power consumption</b>	Power input x average running time
<b>Temperature range</b>	+10°C to -18°C, continuously variable via electronic thermostat with digital temperature display
<b>Insulation</b>	CFC-free PU foam
<b>System</b>	Fully hermetic Danfoss BD35F compressor with integrated control electronics, low-voltage protection, electronic fuse/automatic reverse pole protection, dynamically ventilated wire tube condenser, aluminium rollbond evaporator
<b>Material</b>	Cabinet: PP, lid: PE
<b>Colour</b>	Body: pale grey/dark grey; lid: dark grey
<b>Weight</b>	approx. 24 kg
<b>Quality features</b>	Intelligent battery monitor to prevent excessive discharging of the vehicle battery, display with digital temperature readout, temperature adjustable with two buttons in 1°C steps, simultaneous charging and cooling, battery charging state indicated by LED, battery low warning
<b>Scope of delivery</b>	DC connection cable, wire basket, detachable carrying handles
<b>Test marks</b>	CE, TÜV/GS, E-approved according to UN-ECE R10 directive

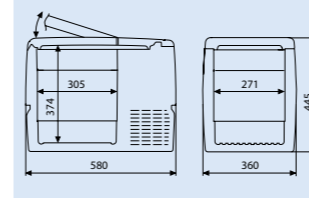

Product	Ref. No.
CoolFreeze CF-32UP	9105100001
<b>Optional extras:</b>	
Mains adapter 110 – 240 V > 24 V	MPS-50
Fridge slide, long	SLD-060
Fridge slide, wide	SLD-060W
Universal fixing kit	UFK-C

Temperature range  
+10°C to -18°C

Suitable for solar operation

With integrated battery for up to 18 hours operation without external power

Fridge slides and fixing kit as accessories (pages 44 – 45)

230-volt connection with low-priced mains adapters (pages 90 – 93)

An extra control panel for the battery: ON/OFF switch, LED display showing the battery charging state

**Fridge slides, long and wide version**

For CoolFreeze CF-32UP / CF-35 / CF-40 / CF-50 / CF-60

For fastening of WAECO CoolFreeze coolers in vehicles and for convenient loading and unloading

4.10



<b>Material / Colour</b>	Powder coated metal / grey
<b>Weight</b>	11.5 kg
<b>Dimensions (W x H x D) mm</b>	<b>SLD-060</b>
	Retracted: 421 x 85.4 x 760 Extended: 421 x 85.4 x 1418
	<b>SLD-060W</b>
	Retracted: 789 x 85.3 x 475 Extended: 789 x 85.3 x 938
<b>Quality features</b>	50 kg max. load capability, tie-down straps included in the set
<b>Product Ref. No.</b>	
Fridge slide, long for CF-32UP / CF-35 / 40 / 50 / 60	SLD-060
Fridge slide, wide for CF-32UP / CF-35 / 40 / 50 / 60	SLD-060W

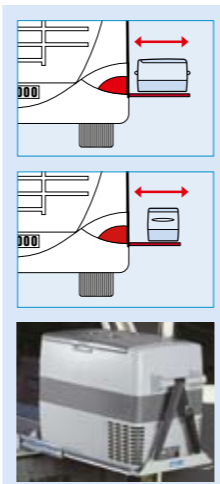

**Fridge slides, long and wide version**

For CoolFreeze CF-80 / CF-110

For fastening of WAECO CoolFreeze coolers in vehicles and for convenient loading and unloading

4.10



<b>Material / Colour</b>	Powder coated metal / grey
<b>Weight</b>	19.4 kg
<b>Dimensions (W x H x D) mm</b>	<b>SLD-110</b>
	Retracted: 574 x 85.4 x 909 Extended: 574 x 85.4 x 1677
	<b>SLD-110W</b>
	Retracted: 939 x 85.3 x 690 Extended: 939 x 85.3 x 1368
<b>Quality features</b>	100 kg max load capability, tie-down straps included in the set
<b>Product Ref. No.</b>	
Fridge slide, long for CF-80 / 110	SLD-110
Fridge slide, wide for CF-80 / 110	SLD-110W

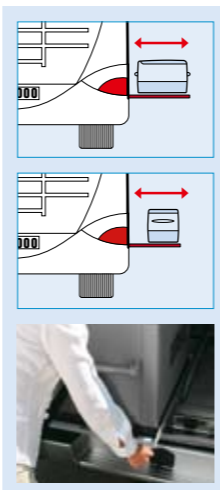

**Universal fixing kit**

For CoolFreeze CDF-25, CF-32UP, CF-35, CF-40, CF-50, CF-60

For fastening of WAECO CoolFreeze coolers in vehicles

4.10

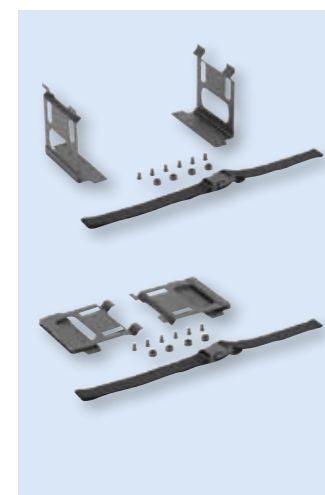

<b>Material</b>	Powder coated metal
<b>Colour</b>	Black
<b>Scope of delivery</b>	Two frame sections, adjustable strap with snap lock, set of screws
<b>Product Ref. No.</b>	
Universal fixing kit	UFK-C



**Protective covers for CoolFreeze coolers**

The functional all-round protection for your coolers

Does the zest for outdoor adventure take you over rough terrain at times? Go ahead, the **insulating protective cover** makes your CoolFreeze cooler fit for tough challenges. The cover protects the valuable appliance from moisture, dust and dirt. It also provides effective insulation, improving the unit's cooling capacity by a full 2°C – at the same energy consumption. The robust and functional all-round protection is available for CoolFreeze models CDF-18 / 25 and CF-35 to CF-110.



**Insulating protective covers**

For CoolFreeze CDF-18, CDF-25, CF-35, CF-40, CF-50, CF-60, CF-80, CF-110

4.10



<b>Material, outside</b>	High-quality silver-grey Oxford nylon, lid and base in robust, rubber coated, black nylon
<b>Material, inside</b>	Aluminium coated polyester
<b>Colour, sides</b>	Silver grey
<b>Colour, lid and base</b>	Black
<b>Quality features</b>	Detachable lid and base, outside pockets to store small items, four fixing rings to secure the box safely in the vehicle

Extra protection and insulation for your cooler

Product	Weight (kg)	Ref. No.
Protective cover for CoolFreeze CDF-18	approx 1.0	IC-CF-18
Protective cover for CoolFreeze CDF-25	approx 1.1	IC-CF-25
Protective cover for CoolFreeze CF-35	approx 1.3	IC-CF-35
Protective cover for CoolFreeze CF-40	approx 1.5	IC-CF-40
Protective cover for CoolFreeze CF-50	approx 2.0	IC-CF-50
Protective cover for CoolFreeze CF-60	approx 2.0	IC-CF-60
Protective cover for CoolFreeze CF-80	approx 2.2	IC-CF-80
Protective cover for CoolFreeze CF-110	approx 2.4	IC-CF-110



Direct access to the controls ...



... and connection sockets



Practical outside pockets for small items



Top insulation in aluminium coated polyester





## Built-in coolers for mobile kitchens

Cooling comfort in confined spaces

**There's no space left on board your motorhome or yacht to accommodate a refrigerator?** Take a look at CoolMatic CB, two built-in coolers specifically designed for permanent fitting in confined spaces. Where height and width is limited, they use the depth of the cupboard space instead. In this way, they make optimum use of the available space, while perfectly matching the design of the interior.

A smart solution in confined spaces: the cooling unit can be fitted to the side of the cooler (left/right), or up to 1.5 metres away.

### CoolMatic CB-36 / CB-40

A matching built-in cooler for every demand:

**CoolMatic CB-36 and CB-40 with 36 or 40 litres volume for refrigeration and deep-freeze cooling.** Both units owe their **extraordinary performance** to the tried and tested **Danfoss BD35F compressor**. This high-tech compressor ensures **minimal power consumption, impeccable operation in inclined positions and superbly quiet running.**

Designed for **connection to 12/24 volts** (automatic switch-over), the appliances are perfectly suited for operation with a solar unit. The energy required for cooling can just as easily come from the mains hook up. All you have to do is connect the low-priced mains adapter.



### WAECO CoolMatic CB-36 / CB-40

Built-in coolers for mobile kitchens

4.12



CB-36

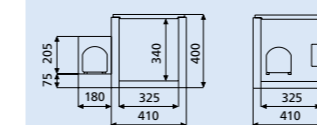

CB-40

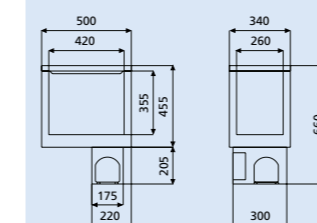

	CB-36	CB-40
<b>Gross capacity</b>	approx. 36 litres	approx. 40 litres
<b>Voltage</b>	12/24 volts DC	
<b>Average Power consumption</b>	approx. 45 watts	
<b>Average running time</b>	15% at +20°C ambient temperature, 25% at +32°C ambient temperature, both at +5°C interior temperature	17% at +20°C ambient temperature, 27% at +32°C ambient temperature, both at +5°C interior temperature
<b>Power consumption</b>	Power input x average running time	
<b>Temperature range</b>	From normal refrigeration to **-deep-freezing	
<b>Insulation</b>	40 mm solid polyurethane foam	
<b>System</b>	Fully hermetic Danfoss BD35F compressor with integrated control electronics, low-voltage protection, electronic fuse/automatic reverse pole protection, detachable cooling unit (1.5 m supply cable), three-sided, statically ventilated wire tube condenser mounted on a base plate	
	foamed tubular evaporator fitted inside (invisible)	foamed aluminium rollbond evaporator (invisible)
<b>Material</b>	Outside: zinc coated sheet steel, inside: stainless steel, base: shock-resistant plastic	
<b>Colour</b>	Body: grey, decor panel: pale grey	
<b>Weight</b>	18.5 kg	20.0 kg
<b>Quality features</b>	Separate lid inside with sealing and insulation	
<b>Test marks</b>	CE, e-approved according to 2006/28/EC (Automotive EMC Directive)	



From normal refrigeration to \*\*-deep-freezing



Suitable for solar operation

Cool solutions in confined spaces

Room for 2-litre bottles standing upright

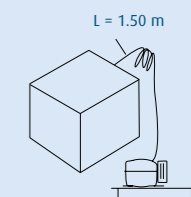

Detachable cooling unit (1.5 m supply cable)

230-volt connection with low-priced mains adapters (pages 90 - 93)

Product	Ref. No.
CoolMatic CB-36	CB-036
CoolMatic CB-40	CB-040
<b>Optional extras</b>	
Mains adapter 230 V > 24 V	EPS-100W
Mains adapter 110 - 240 V > 24 V	MPS-35

### Compact and adaptable

One of them is bound to fit the space: the CoolMatic CB-36 with the cooling unit attached to the side, or the CB-40 with the attachment underneath. Where space is restricted, the cooling units can be detached and installed up to 1.5 m away.

For elegant aesthetics, the lids can be supplied with decors to match the interior design of your onboard kitchen.

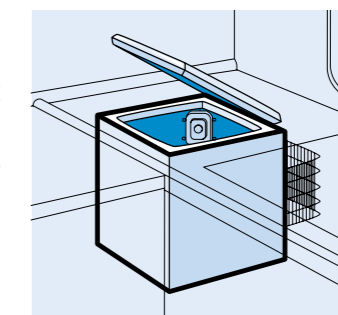

Plenty of space lengthwise? Then take the CB-36 with the cooling unit attached to the side.

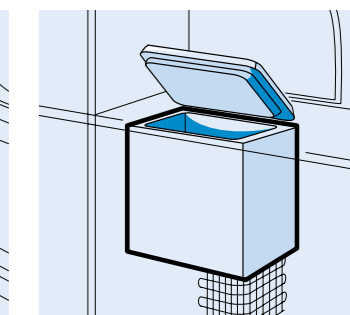

Space to spare in the depth? That makes the CB-40 the ideal solution.